

Nuclear Associates

CLEAR-Pb[®] Transparent X-Ray Compensation Filters for Spinal Radiography

Instruction Manual



CardinalHealth

(Blank page)

Contents

Section 1:	General Information.....	1-1
1.1	Introduction	1-1
Section 2:	Applications & Specifications	2-1
2.1	Applications & Specifications	2-1
Section 3:	Filter Holder Mounting Instructions	3-1
3.1	Filter Holder Mounting Instructions	3-1
Section 4:	Filter Positioning (General).....	4-1
4.1	Filter Positioning (General).....	4-1
Section 5:	Detailed Filter Positioning	5-1
5.1	AP Full Spine 13 cm and Under (Small to Average Patient) (72" FFD).....	5-1
5.2	AP Full Spine 14-19 cm (Above Average Patient) (72" FFD)	5-2
5.3	AP Full Spine 20-25 cm (Large Patient) (72" FFD).....	5-4
5.4	AP Full Spine Over 25 cm (Very Large Patient) (72" FFD).....	5-5
5.5	AP Lateral Cervical Spine (72" FFD)	5-6
5.6	Lateral Thoracic Spine (40" FFD)	5-7
5.7	Lateral Full Spine (Single Exposure).....	5-8
5.8	AP Thoracic Spine (40" FFD)	5-9
5.9	AP Erect Abdominal Examination (40" FFD).....	5-10
5.10	Lateral Lumbar Spine (L5-S1) Interspace (30" FFD)	5-11
5.11	Slim Lateral Spot for C7 (30" FFD)	5-12
5.12	Shoulder (40" FFD).....	5-13
5.13	Ribs (40" FFD).....	5-14

(Blank page)

General Information

1.1 INTRODUCTION

CLEAR-Pb Compensation Filters are made of a lead-plastic material that is 30% lead by weight. Since lead is an efficient absorber of x-rays, the filters will attenuate the x-ray beam. By varying the shape and thickness of the filters, many combinations of filtering action can be achieved...from almost complete attenuation to full penetration. (See Figure 1-1.)

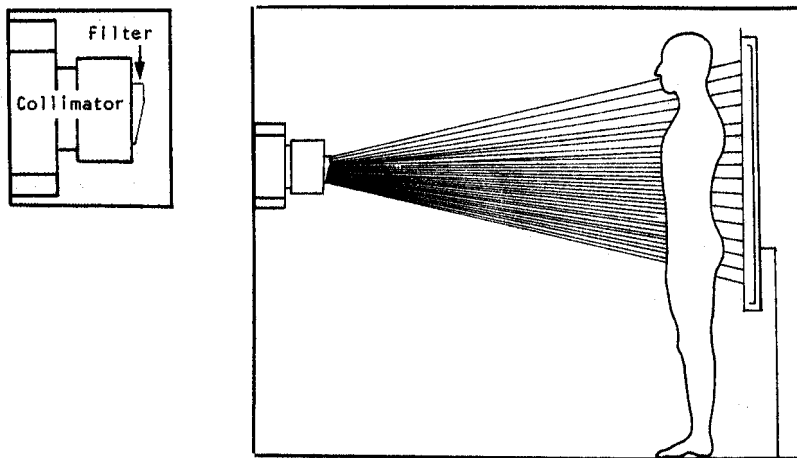

Figure 1-1 Filters Attenuate X-ray Beam to Provide Even Exposure Throughout Image Area

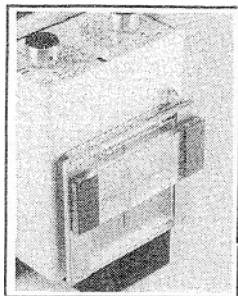

Figure 2-2 Collimator with Filter Holder (57-426) and AP/PA Wedge (57-405) in Place

CLEAR-Pb Filters are transparent and lightweight. By means of our "Quick-Stik" system of magnetic strips on the filters, and a filter holder that slides into the collimator's accessory tray, the filters can be held firmly in place and repositioned instantly. (See Figure 2-2) You can see and adjust the area and/or degree of filter coverage as necessary. Last-minute positioning checks of the patient, x-ray collimator, and filters are possible, thanks to the filter transparency. Selected-area beam shaping has never been so simple and effective.

CLEAR-Pb Filters should be used with a rare-earth film/screen combination to improve image quality and keep patient exposure to a minimum. CLEAR-Pb Compensation Filters are not compatible with gradient speed intensifying screens. Consult your film manufacturer for the proper film/screen combination. This instruction manual provides typical suggested procedures for using CLEAR-Pb Compensation Filters. However, individuals may modify this technique to suit their own requirements.

Applications & Specifications

2.1 Applications & Specifications

The filters and accessories are available individually or as a set (57-445). The 57-445 CLEAR-Pb X-Ray Compensation Filter Set includes a multi-purpose AP/PA wedge filter (72" FFD), a lateral cervical filter, a lateral thoracic filter, a pediatric and adult gonad shield, a breast shield assembly, two AP/PA build-up filters (one thick, one thin), a filter holder, and two mounting plates. A 40" FFD AP/PA wedge Filter is optional. Filters purchased individually require a filter holder (56-426) to make them compatible with the x-ray collimator. One filter holder (with mounting plates) is recommended for each x-ray machine. All Filters have magnetic mounting strips at each end to attach to the matching steel rails on the filter holder.

AP/PA Wedge Filter (72" FFD)

Model 57-405: Size 6 ½" long x 2 ¼" wide x 3/8" thick; weighs 6 oz.

AP/PA Wedge Filter (40" FFD)

Model 57-415: Identical to Model 57-405 except that it is 4-1/8" wide; weighs 10 oz.

Lateral Cervical Filter (72" FFD)

Model 57-406: 6 ½" long x 1 ¼" wide x 3/8" thick; weighs 4 oz.

Lateral Thoracic Filter (72" FFD)

Model 57-407: 6 ½" long x 1 ¼" wide x 3/8" thick; weighs 4 oz.

Breast Shields

Model 57-409: 3" long x 3" wide x 1/8" thick; weighs 2 oz. Will attach to Model 57-426 filter holder with or without the use of a filter (set of 2 pieces).

Build-Up Filter AP/PA (Thin)

Model 57-430: 6 ½" long x 1 ¼" wide x 1/8" thick. Has magnetic tape on one side, steel on the opposite side, to allow filter stacking; weighs 2 oz.

Build-Up Filter AP/PA (Thick)

Model 57-434: 6 ½" long x 1 ¼" wide x 9/32" thick. Has magnetic tape on one side, steel on the opposite side, to allow for filter stacking; weighs 3 oz.

Filter Holder

Model 57-426: Clear plastic, 6 ½" wide x 5 ½" long x ¼" thick. Has two steel rails, 1" wide x 5 ½" long, for positioning filters and shields. Only one filter holder is needed per x-ray machine.

Mounting Plates





Model 57-411: Clear plastic, 9" long x 9" wide x 1/16" thick. Attached to filter holder with screws. Easily cut to fit collimator assembly. Two mounting plates are included with each filter holder assembly.



Gonad Shield

Adult, Model 57-408: 6 ½" long x 1" wide x 1/16" thick. Has a shamrock-shaped, 0.030" thick lead shield made up of three overlapping circles, each ½" diameter; weighs ½ oz.

Gonad Shield

Pediatric, Model 57-444: 6 ½" long x 1" wide x 1/16" thick. Has shamrock-shaped, 0.030" thick lead shield made of three overlapping circles, each ¼" diameter; weighs ¼ oz. Also for imaging sacroiliac region of adult female.

Filter	AP/PA (72" FFD)	AP/PA (40" FFD)	Lateral Thoracic	Lateral Cervical
Model No.	57-405	57-415	57-407	57-406
Applications	Full spine, AP or PA AP or oblique esophagram Lateral chest	Full spine, AP or PA	Lat. full spine Oblique or AP esophagram (obese patients) Angiography of neck, lower head (may need 2 filters)	Lat. cerv. spine Lat. full spine (with 57-407 Filter) Lateral aortic arch
Length x Width Max. Thickness Trough Width	6.5" L x 2.25" W 0.1" —	6.5" L x 4.125" W 0.1" —	6.5" L x 1.25" W 0.15" —	6.5" L x 1.25" W 0.3" —
Configuration Filter Materials <input type="checkbox"/> Plastic <input checked="" type="checkbox"/> Lead-Plastic <input checked="" type="checkbox"/> Magnetic Tape				

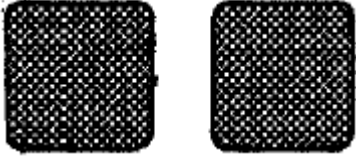
Filter	Build-Up (Thin)	Build-Up (Thick)	Breast Shields
Model No.	57-430	57-434	57-409
Applications	Additional Filtration to even out density in cervical area.	Additional filtration to even out density in cervical area.	Full-body shielding when imaging the full spine. Permits vertical and horizontal adjustment of shielded area.
Length x Width Max. Thickness	6.5" L x 1.25" W 0.125"	6.5" L x 4.125" W 0.28"	3" L x 3" W 0.12"
Configuration Filter Materials <input type="checkbox"/> Plastic <input checked="" type="checkbox"/> Lead-Plastic <input checked="" type="checkbox"/> Magnetic Tape <input checked="" type="checkbox"/> Shield			

(Blank page)

Filter Holder Mounting Instructions

3.1 Filter Holder Mounting Instructions

If the collimator housing has an accessory tray, the two 9" x 9" X 1/16" acrylic mounting plates (held together by 4 screws) should be cut to fit the rails of the tray (Figure 3-2). If the tray channel is less than 1/8" wide, only one of the mounting plates is required. The other should be removed and retained as a spare.

To separate the filter holder from the mounting plate(s), remove the four small screws holding them together (Figure 3-1). Carefully measure the collimator's accessory tray and mark one or both of the mounting plates for cutting. A cardboard template is recommended as a cutting guide. Make a trial fitting with the template before cutting the plastic to ensure that the filter holder will be in the proper position on the mounting plate. If the final shape of the mounting plate is not square, be sure to check for proper longitudinal orientation of the filter holder (Figure 3-2).

To cut the plastic mounting plate(s), use a plastic scoring knife. Cut each plate separately. Score the plastic at the desired locations, making sure that each score runs the full length (width) of the plate. Make the scores deep by going over each scratch several times.

Next, place the scored plate over the edge of a table, with the score mark on top and exactly above the edge. Hold the plastic sheet flat to the table top with one hand. With the other hand, bend the overhanging part of the plastic sheet down. If the score mark lines up exactly at the table edge, the overhanging piece will break cleanly at the mark.

Check that the mounting plate slides easily into the accessory tray. To make any fine adjustments needed for a proper fit, use a file or fine sandpaper.

Re-attach the filter holder to the mounting plate(s), and insert the assembly into the collimator's accessory tray (Figure 3-2). If your collimator does not have an accessory tray, the filter holder may be mounted with self-stick Velcro-type material. This attachment kit (Model 57-426-1100) is available from Cardinal Health.

If the steel rails on the filter holder intrude into the x-ray field of view, unscrew the rails and turn them around (Figure 3-3). Since the screw holes in these rails are off center, turning the rails will set them 3/4" further apart.

If desired, the magnetic tape on some or all of the filters can be cut to match the new position of the holder rails. Using a sharp knife, cut through the magnetic tape (on each side of the filter) in a line parallel to, and 3/8" from, the inner edge. Remove this 3/8" strip, leaving a 5/8" tape strip along the outer edge of the filter, which matches the new position of the filter holder rails.

The use of the filters and holder is not changed by the above procedure.

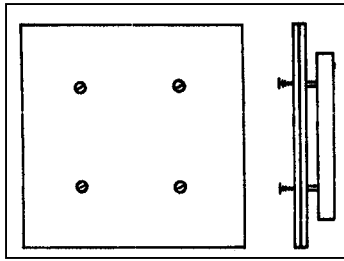

Figure 3-1. Screws Attach Mounting Plates to Filter Holder

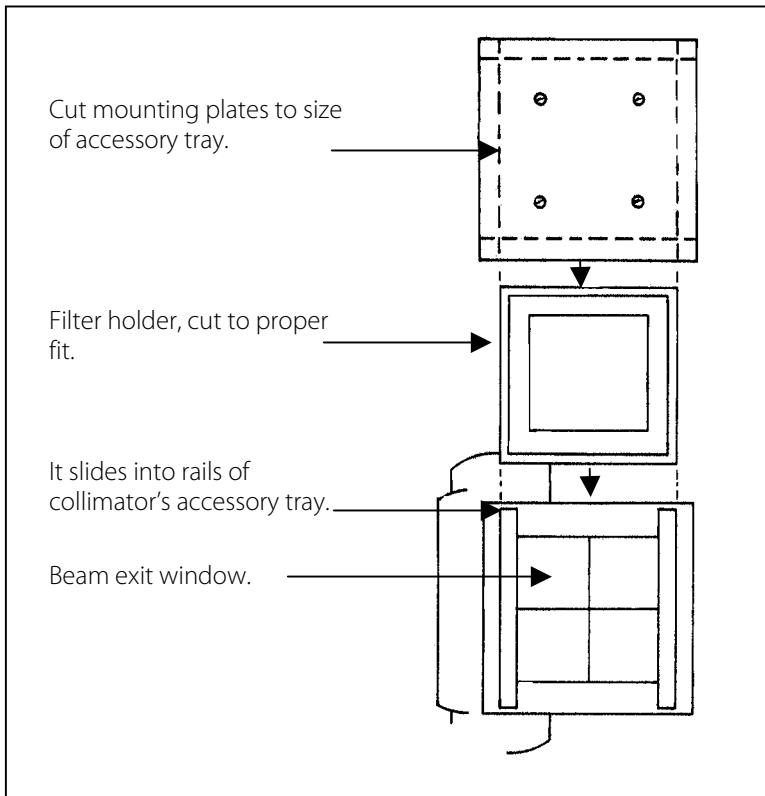

Figure 3-2.

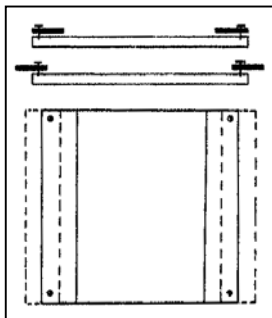

Figure 3-3. Turning the Steel Rails Increases Spacing Between Them

Filter Positioning (General)

4.1 Filter Positioning (General)

This section contains a general description of filter positioning. Read it thoroughly before continuing.

When performing examinations with 72" FFD, a 14" x 36" cassette and preferably rare-earth intensifying screens, proceed as described below. Sectional or multiple view radiographs on 14" x 17" or smaller films may also be taken with the same filter orientation.

1. Position the patient, cassette, and x-ray tube as usual.
2. Attach the appropriate filter to the filter holder by the "Quick Stik" magnetic system. The magnetic tape on the filters should align with the steel rails on the filter holder assembly. Adjust to the proper height by sliding it up and down. The transparency of CLEAR-Pb filters allows the use of the collimator light. However, shadow lines or the filter edges are clearly identifiable to aid in correct placement. Either side of the filter can be outward.
3. Position the Breast Shields on top of the filter by attaching the steel side of the Breast Shields to the magnetic mounting material at both sides of the filter.

Please Note: The Breast Shields may be used without a filter by simply attaching the magnetic side of the Breast Shields to the filter holder rails.

Also, when using Build-Up Filters (57-430 and/or 57-434), you might prefer first attaching the Breast Shields (magnetic side) to the filter holder rails, then positioning the AP/PA Filter over the Breast Shields, and attaching the Build-Up Filter (metal side) over the AP/PA Filter.

4. Turn on the collimator light and position the filter so that the top edge of its shadow is at the level of the external auditory meatus.
5. Position the Gonad Shield on the steel rails, using the shadow projected on the patient. Apply the shamrock-shaped lead shield, with the single leaf pointing cephalad for male patients and caudad for females.

NOTE

The inferior aspect of the sacroiliac joints will be blocked on females. This does not apply for use on males.

6. When radiographing the sacroiliac region of an adult female, use the smaller-diameter Pediatric Gonad Shield (57-444).
7. Double check the filter position before exposing the film.

(Blank page)

Detailed Filter Positioning

5.1 AP Full Spine 13 cm and Under (Small to Average Patient) (72"FFD)

Breast Shields (57-409)

AP/PA Wedge Filter (57-405)

Gonad Shield (57-408) or (57-444)

For smaller patients, position the filter 1" above the level of the external auditory meatus. This will result in reduced (filtered) exposure to the neck and upper chest (See Figure 5-1).

The measurement is taken in the AP position at the level of the third lumbar vertebra.

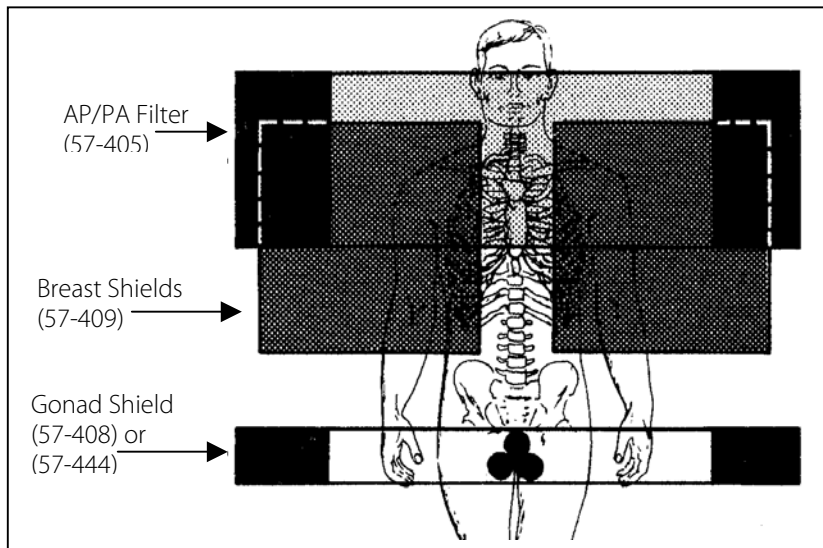

Figure 5-1.

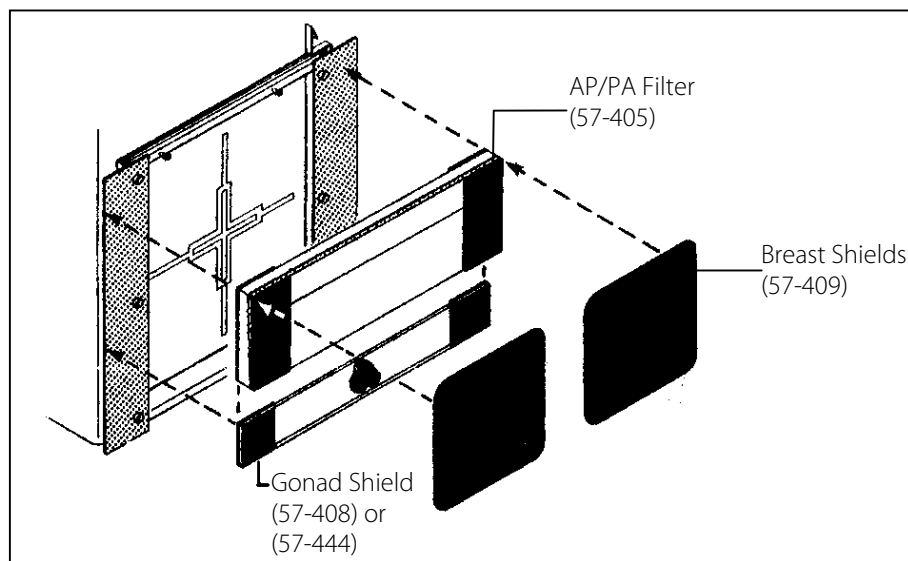

Figure 5-2.

5.2 AP Full Spine 14-19 cm (Above Average Patient) (72" FFD)

AP/PA Filter (57-405)

Build-Up Filter (Thin) (57-430)

Breast Shields (57-409)

Adult Gonad Shield (57-408) or Pediatric Gonad Shield (57-444)

For above average patients, position the AP/PA (57-405) filter 1" above the level of the external auditory meatus. Place the Breast Shields (57-409) on top of the AP/PA wedge (57-405). Place the Thin Build-Up Filter (57-430) on top of the Breast Shields, with the top edge of the filter at the mid-portion of the chin (midway between the inferior alveolar border and the mental protuberance) (See Figure 5-3). The purpose of the Build-Up Filter is to increase the attenuation of the x-ray beam in the cervical area. This is necessary because exposure factors will have to be adjusted to properly expose the lumbar area, due to increased abdominal density. The measurement is taken in the AP position at the level of the third lumbar vertebra

NOTE

When using the Build-Up Filters, always position the steel slide against the magnet. Magnet against magnet will result in filter movement due to repelling magnetic fields.

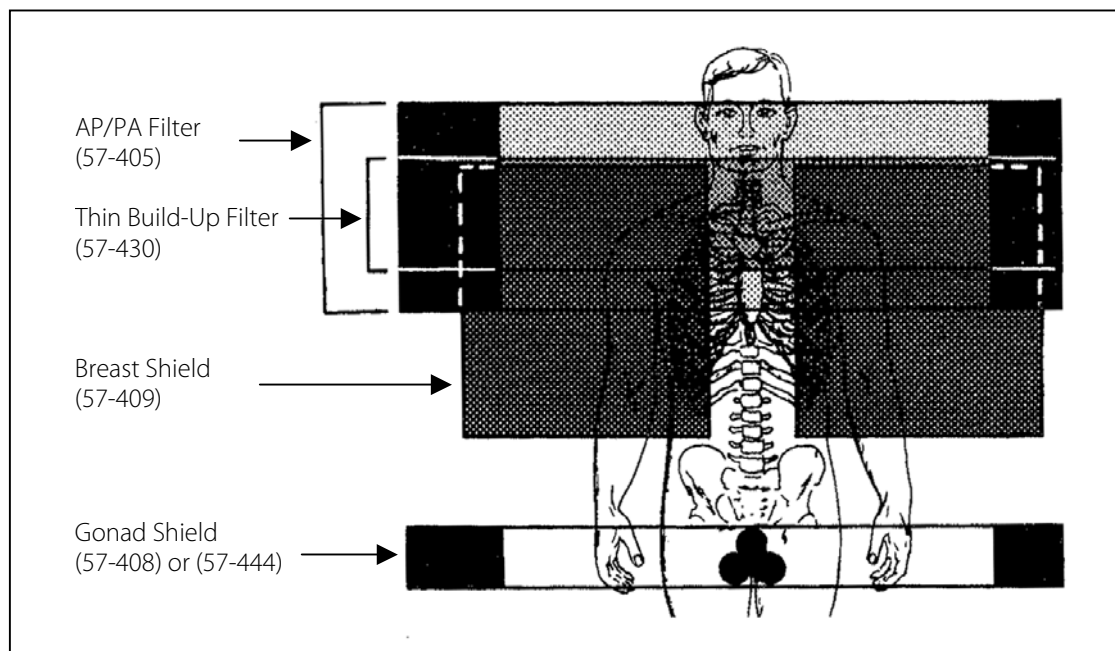

Figure 5-3.

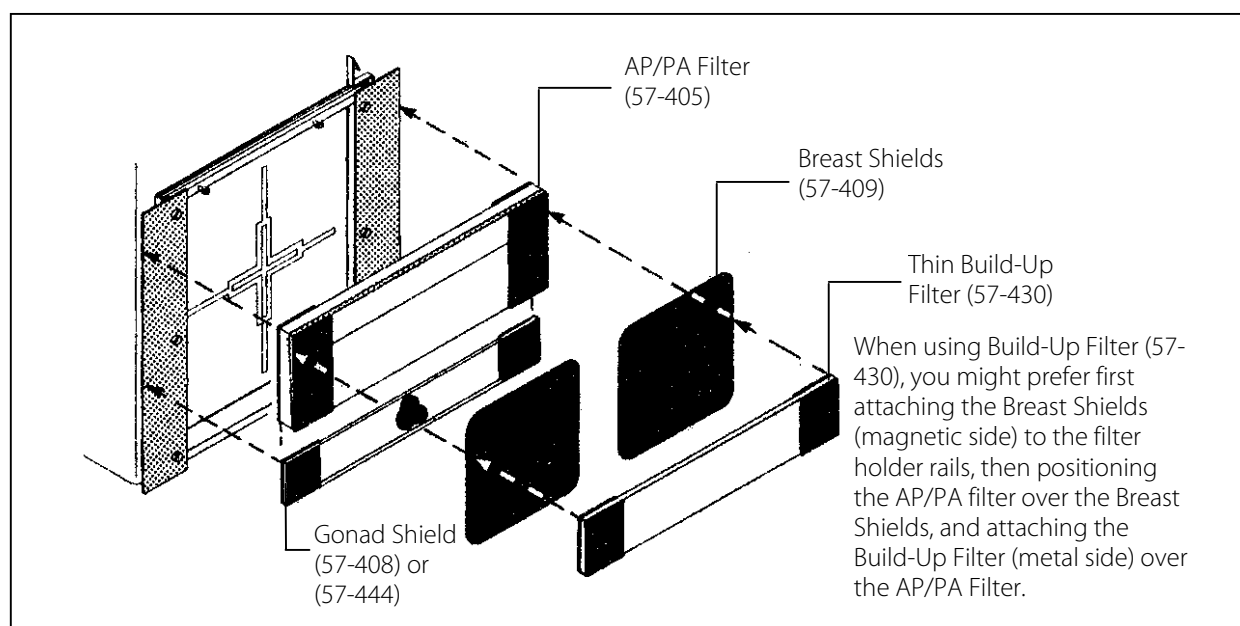

Figure 5-4.

5.3 AP Full Spine 20-25 cm (Large Patient) (72" FFD)

Breast Shields (57-409)

Build-Up Filter (Thin) (57-430)

AP/PA Wedge Filter (57-405)

Gonad Shield (57-408) or (57-444)

Position the top edge of the AP/PA (57-405) Filter at the level of the external auditory meatus. Attach the Breast Shields to the AP/PA Wedge Filter bilaterally. Place the Thin Build-Up Filter (57-430) on top of the Breast Shields, at the base of the nose (see Figure 5-5). The measurement is taken in the AP position at the level of the third lumbar vertebra.

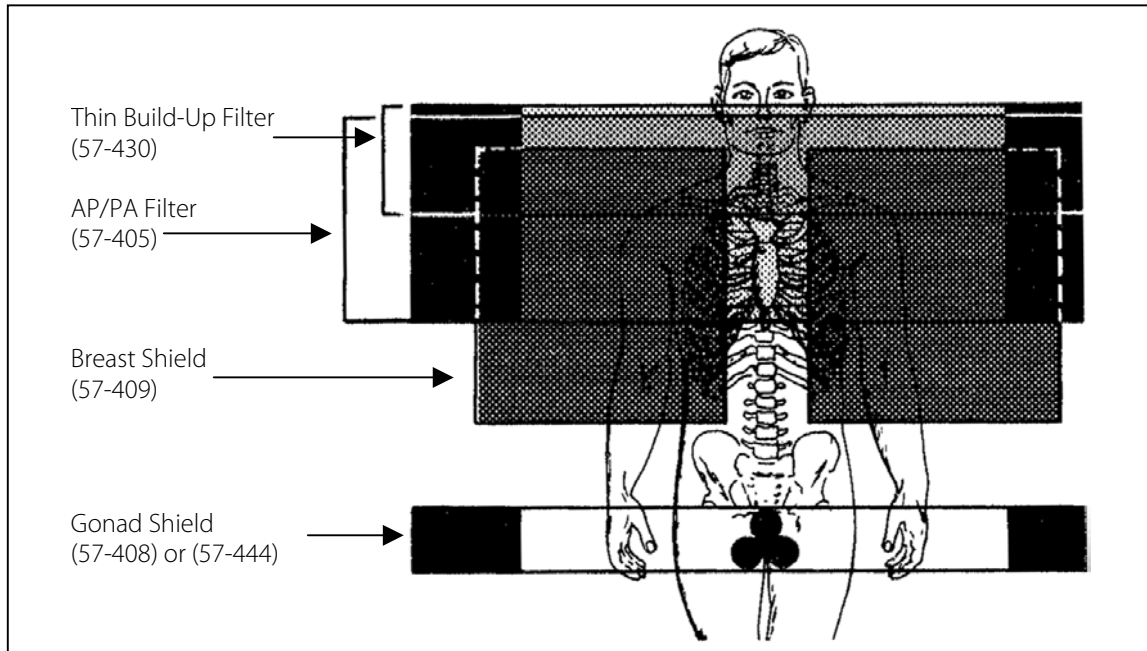

Figure 5-5.

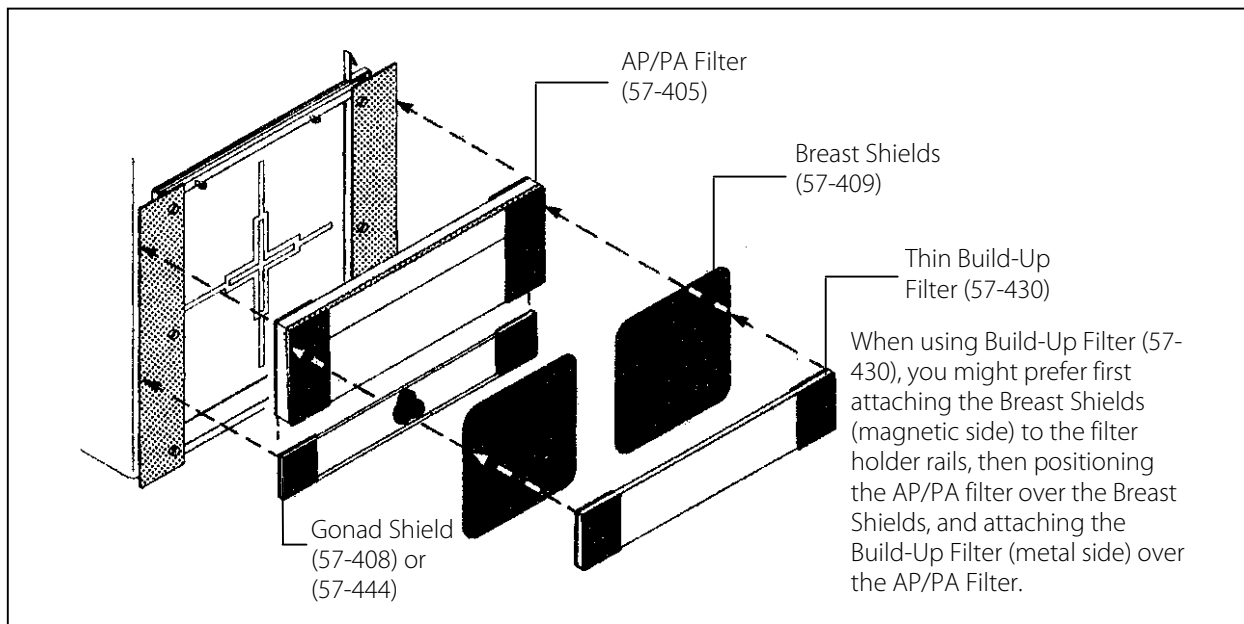

Figure 5-6

5.4 AP Full Spine Over 25 cm (Very Large Patient) (72" FFD)

Breast Shields (57-409)

72" AP/PA Wedge Filter (57-405)

Build-Up Filter (Thick) (57-434)

Build-Up Filter (Thin) (57-430)

Gonad Shield (57-408) or (57-444)

Position the top edge of the AP/PA Filter at the level of the external auditory meatus. Attach the Breast Shields on top of the AP/PA Wedge Filter. Place the Build-Up Filter (thick) on top of the Breast Shields, with the top edge at the base of the nose. Position the Build-Up Filter (thin) on top of the Thick Build-Up Filter to provide additional filtration for the odontoid process (see Figure 5-7). An increase in technique is necessary as the patient measurement increases. The measurement is taken in the AP position at the level of the third lumbar vertebra.

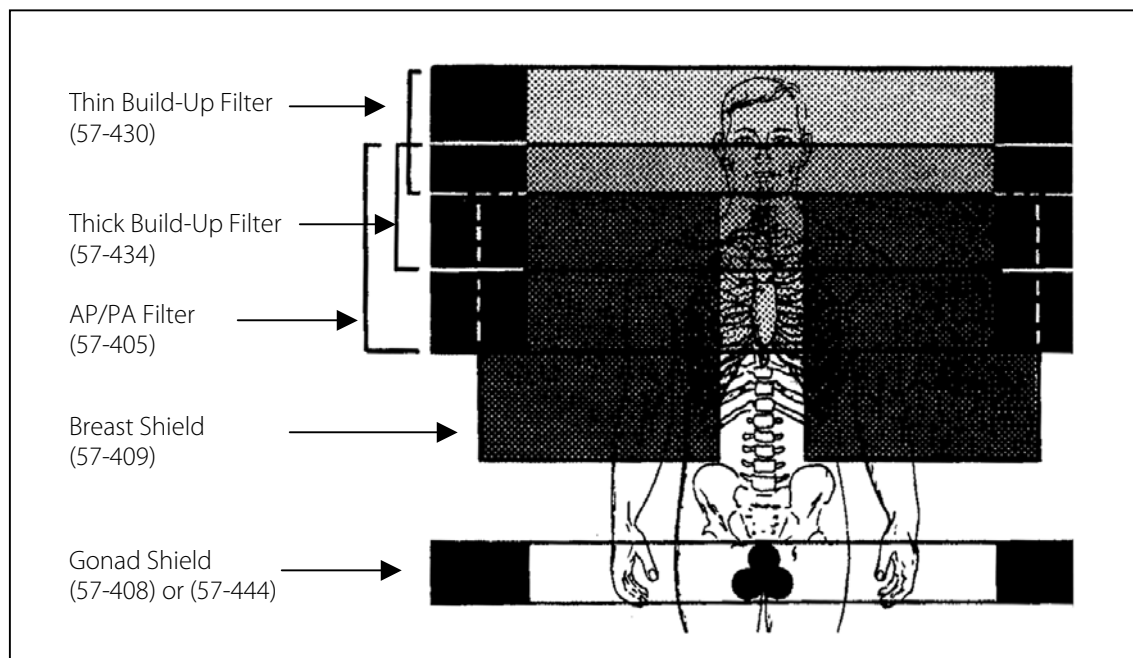

Figure 5-7

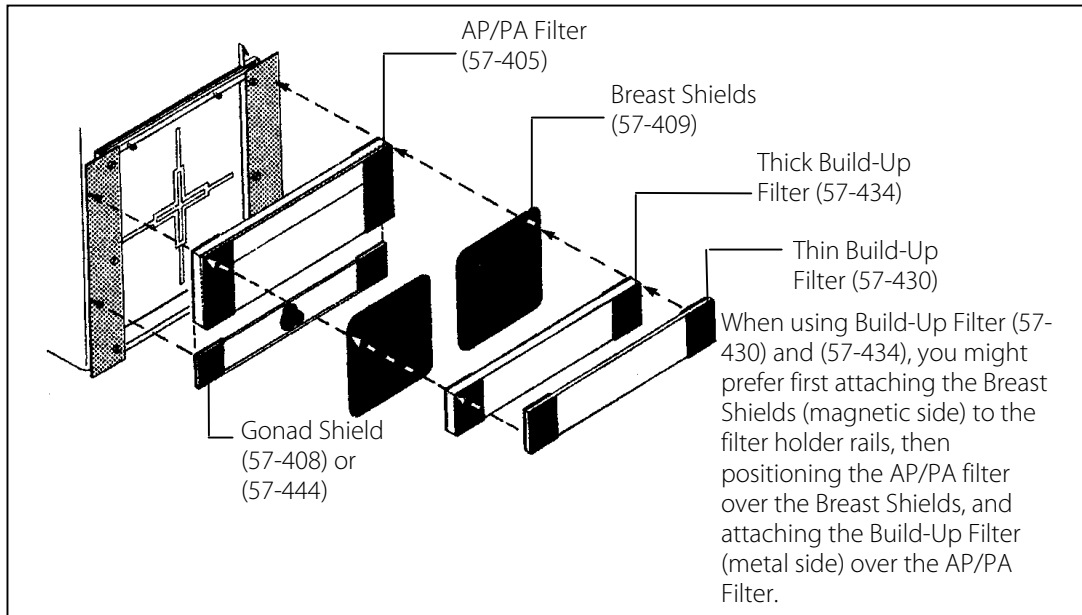

Figure 5-8

5.5 AP Lateral Cervical Spine (72" FFD)

72" Non-Bucky

Lateral Cervical Filter (57-406)

For smaller or average-size patients, no filtration is needed,

For patients with broad shoulders, the Lateral Cervical Filter (57-406) may be indicated. Position it with the shadow of the top edge 1" above the level of the external auditory meatus. The bottom edge should end at the level of the fourth cervical vertebra (see Figure 5-9).

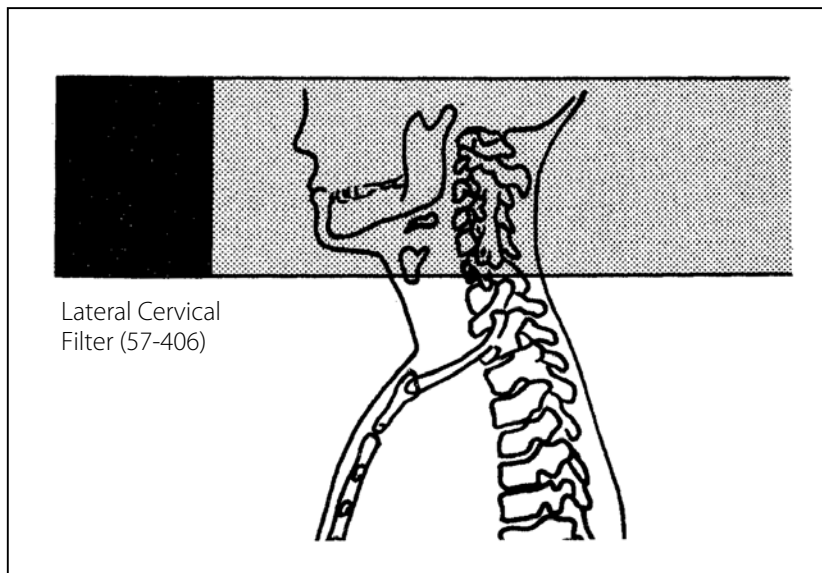

Figure 5-9.

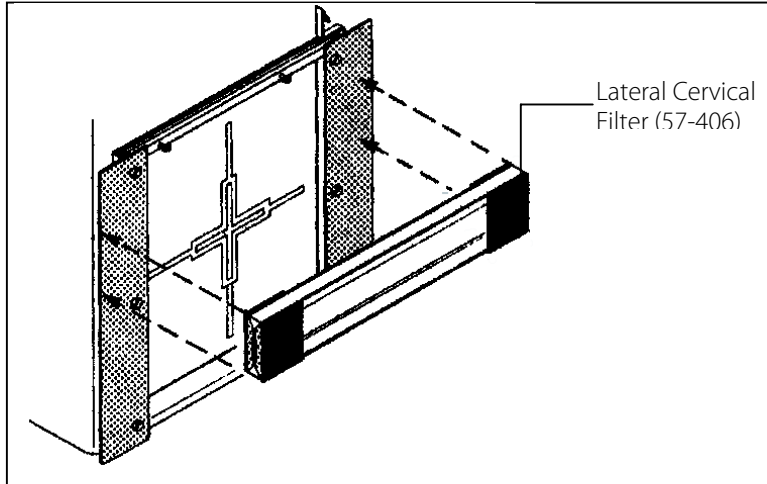

Figure 5-10.

5.6 Lateral Thoracic Spine (40" FFD)

Lateral Thoracic Filter (57-407)

Breast Shields (56-409)

To best visualize the thoracic vertebrae, the humeral heads should project anterior to the thoracic spine. This is done by having the patient place the arms in front of the body, with elbows bent and drawn together, hands supinated perhaps resting on the IV pole to help stabilize the patient.

Attach the Breast Shields to the Filter holder assembly (magnet-to-steel). Place the Lateral Thoracic Filter on top of the Breast Shields.

The Lateral Thoracic Filter is placed to project 1" below the axillary border (see Figure 5-11).

Breathing technique is utilized. Measurement is taken posterior to the humeral heads.

When imaging patients with kyphosis: Take measurement through the kyphosis only, to prevent overexposure.

Collimation 7" x 17".

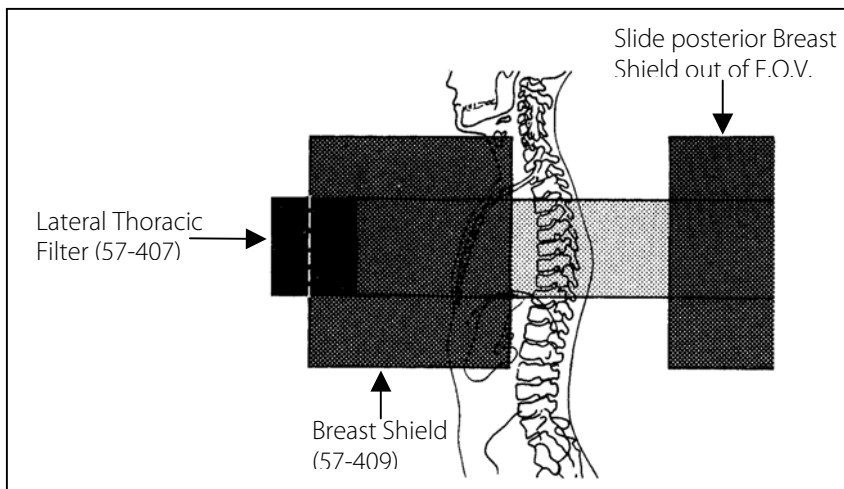

Figure 5-11.

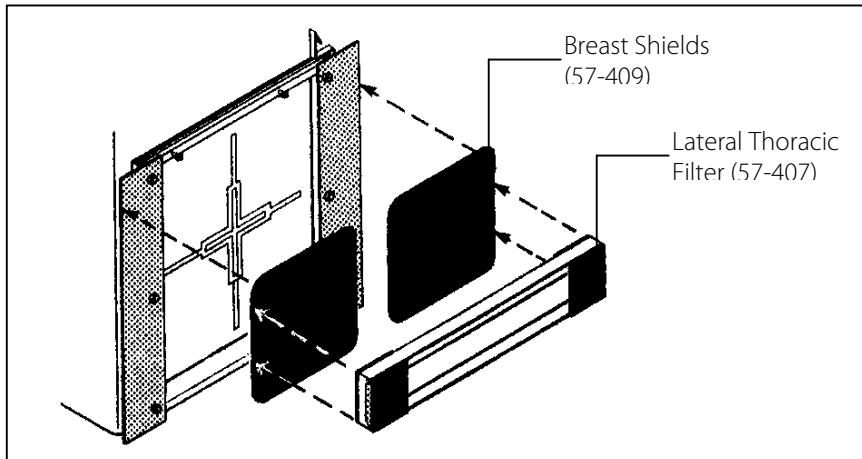

Figure 5-12.

5.7 Lateral Lumbar Spine (40" FFD)

Lateral Thoracic Filter [57-407]

Gonad Shield (57-408) or (57-444)

Used primarily on female patients where the hip measurement is 4-8 cm greater than the waist measurement.

Positioning

Place the bottom edge of the filter just above the iliac crest. Take measurement through the fifth lumbar vertebra (see Figure 5-12).

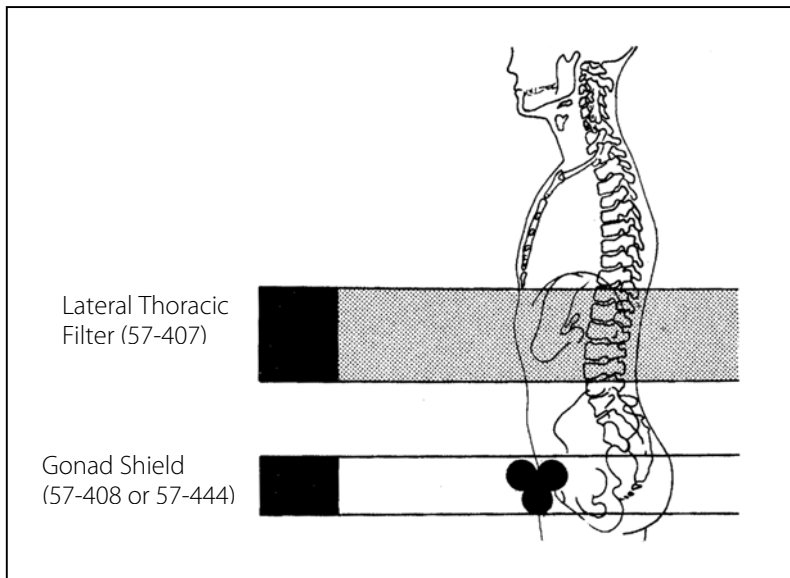

Figure 5-13.

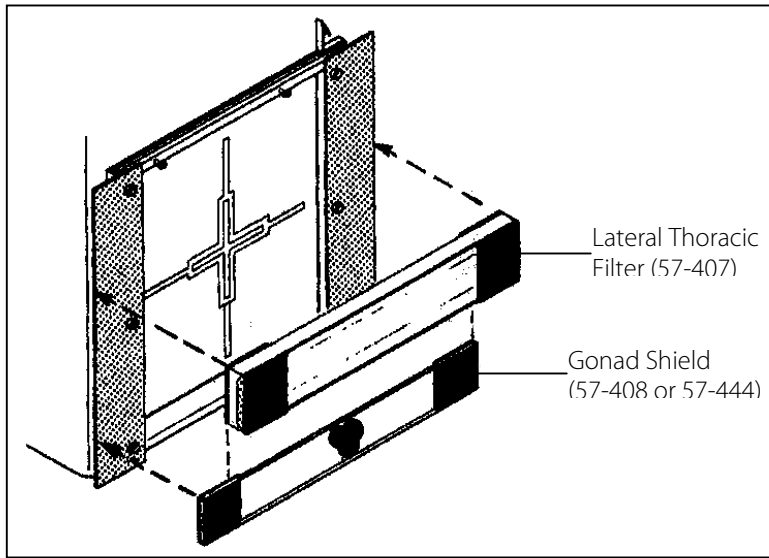

Figure 5-14.

5.8 Lateral Full Spine (Single Exposure)

Lateral Cervical Filter (57-406)

Lateral Thoracic Filter (57-407)

Breast Shield (57-409)

Gonad Shield (57-408) or (57-444)

Positioning

When imaging the full spine in a single exposure, position the Breast Shields (57-409) on top of the filter holder. Slide the posterior shield out of the field of view. Place the Lateral Cervical Filter on the shields, with the top edge of the filter shadow projecting over the external auditory meatus. The bottom edge should end at the level of C-5. Position the Lateral Thoracic Filter, with its top edge 1" below the level of the axillary border (see Figure 5-15). The lumbar area is unfiltered. Technique should be set for the lumbar spine. The Gonad Shield should be positioned as illustrated for males.

For females, raise the shield 4 cm cephalad and 2 cm posterior.

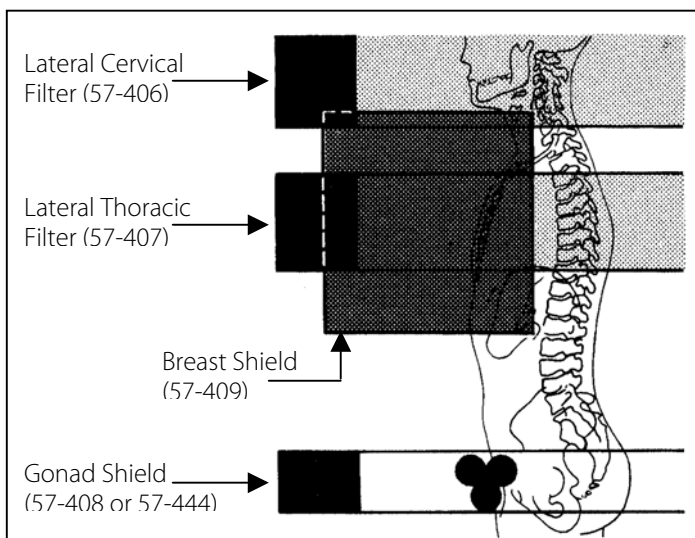

Figure 5-15.

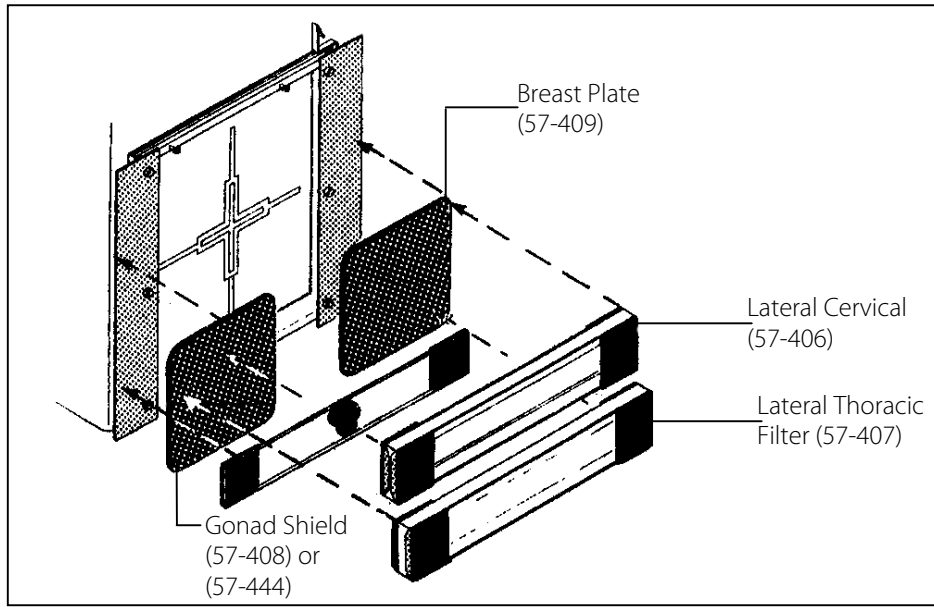

Figure 5-16.

5.9 AP Thoracic Spine (40" FFD)

Breast Shields (57-409)

AP/PA Full Spine Filter (57-415)

Gonad Shield (57-408) or (57-444)

Position the 57-415 (40" FFD) AP/PA Wedge Filter so that the shadow of the filter's thick edge is just above the external auditory meatus (see Figure 5-17). The tapered section of the filter must be in the caudad direction. Attach the Breast Shields (57-409) to both sides of the AP/PA Wedge Filter.

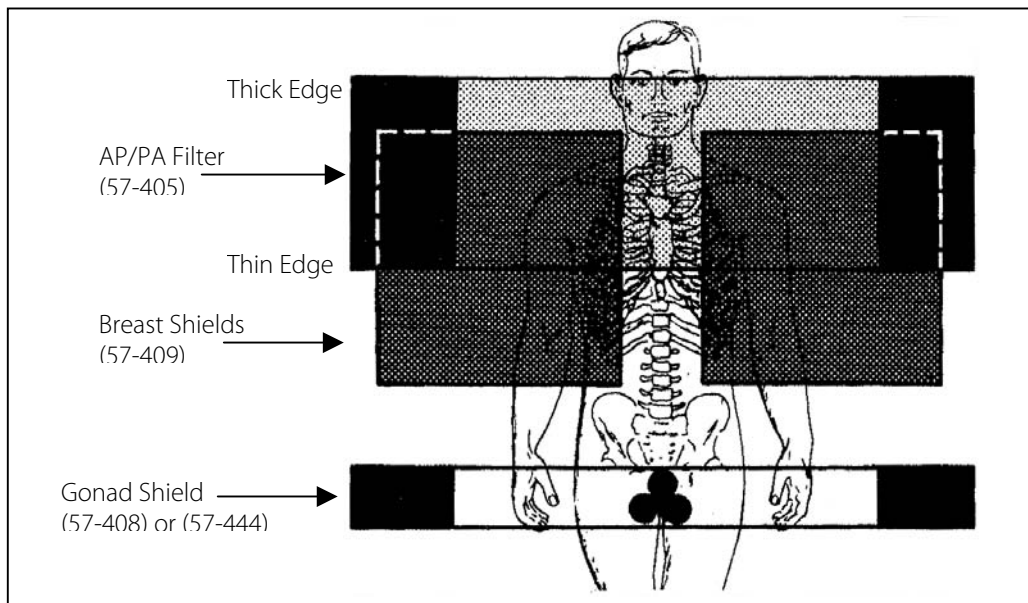

Figure 5-17.

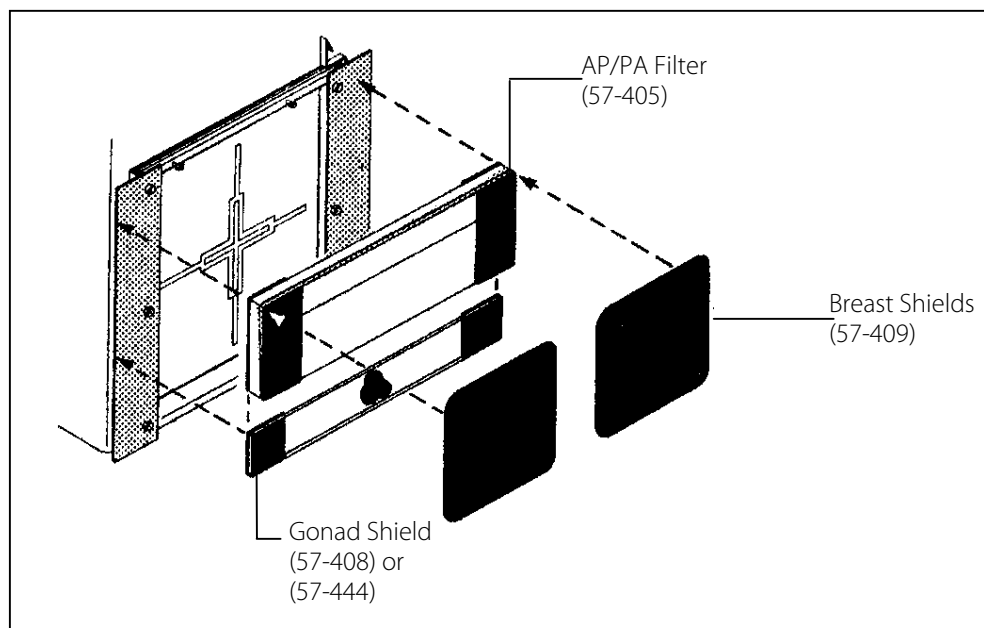

Figure 5-18.

5.10 AP Erect Abdominal Examination

Position the 57-405 AP/PA Wedge Filter so that the shadow of its thick edge projects over the patient's diaphragm. Check that the thin edge of the filter is in the caudad direction (see Figure 5-19). For use on patients with noticeable increased abdominal density.

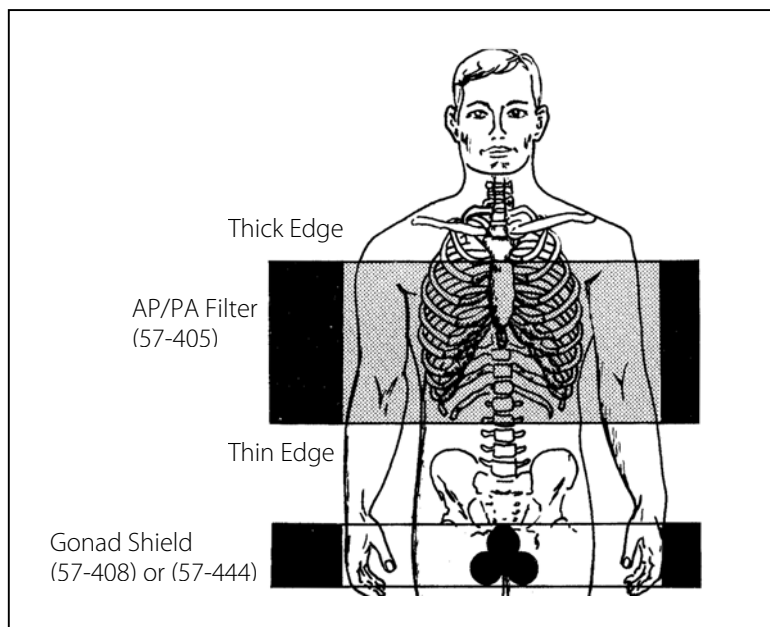

Figure 5-19.

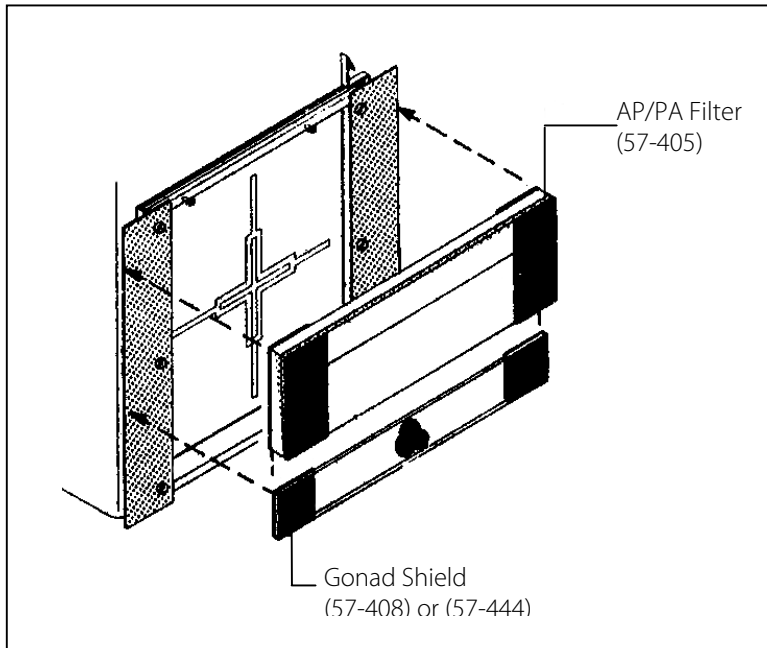

Figure 5-20.

5.11 Lateral Lumbar Spine (L5-S1) Interspace (30" FFD)

Lateral Thoracic Filter (57-407)

Position as the diagram indicates, with the Filter on an angle to allow the top edge to be positioned through the body of the first lumbar vertebra and the bottom edge through the body of the fourth lumbar vertebra (see Figure 5-21).

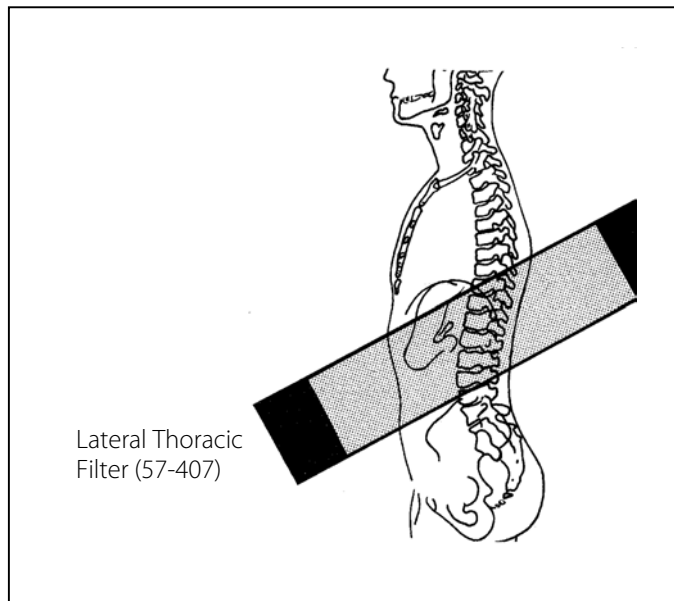

Figure 5-21.

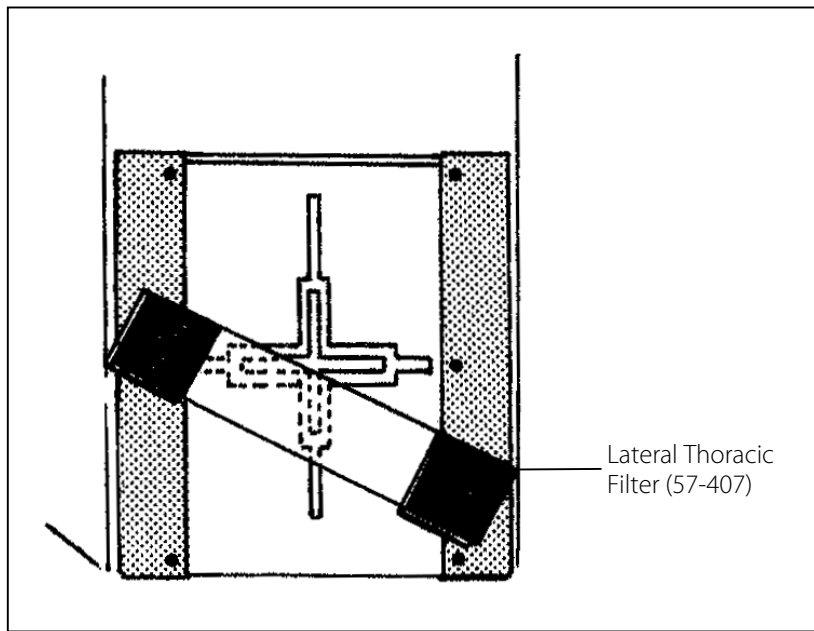

Figure 5-22.

5.12 Slim Lateral Spot for C7 (30" FFD)

Lateral Thoracic Filter (57-407)

Filter the cervical spine above C7 for a more even density throughout the spine. Position the patient in the lateral position. Raise the arm closest to the film, drawing it back under his head as far as possible. Have the patient drop the opposite shoulder by moving his arm posterior to allow the head of the humerus to move posterior. Position the filter on an angle so that the bottom edge of the filter covers the sixth cervical vertebra (see Figure 5-23). Increase technique for C7 as required.

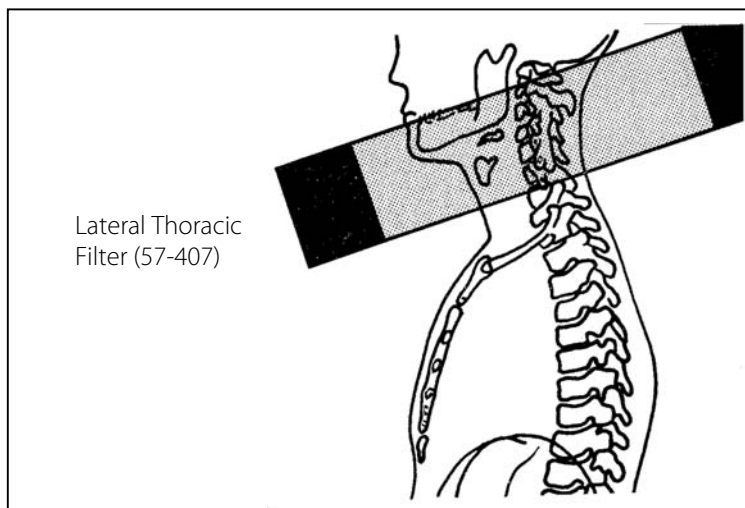

Figure 5-23.

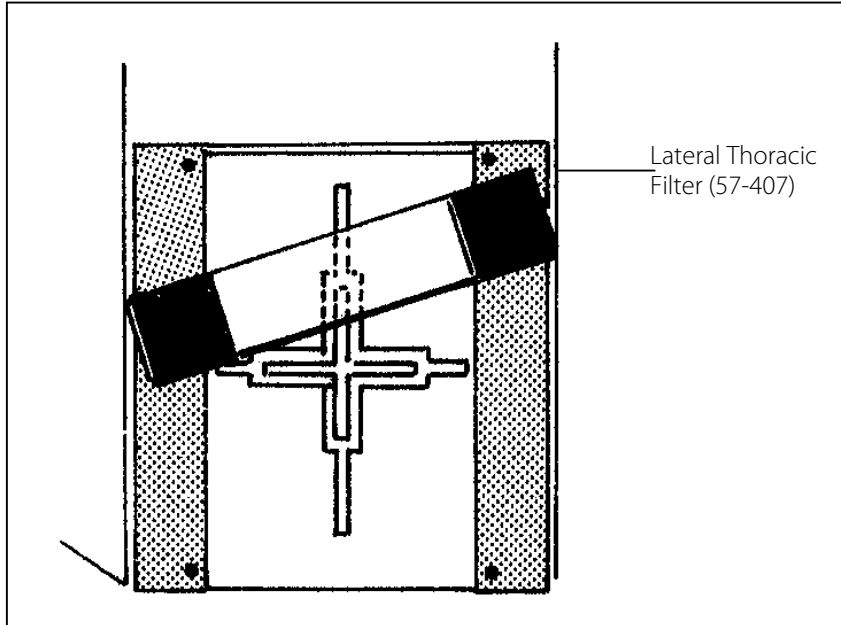

Figure 5-24.

5.12 Shoulder (40" FFD)

Lateral Thoracic Filter (57-407)

Position the patient as usual. Place the Lateral Thoracic Filter so that its bottom edge covers the acromioclavicular joint (see Figure 5-25). There is no change in technique.

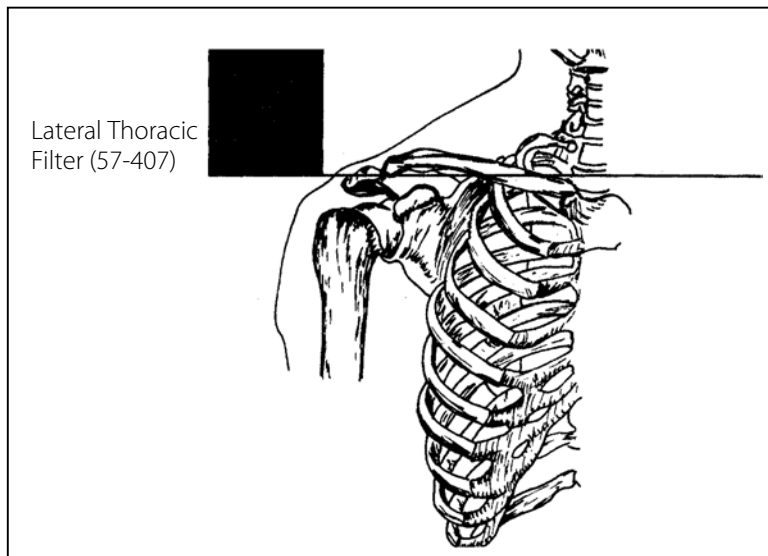

Figure 5-25.

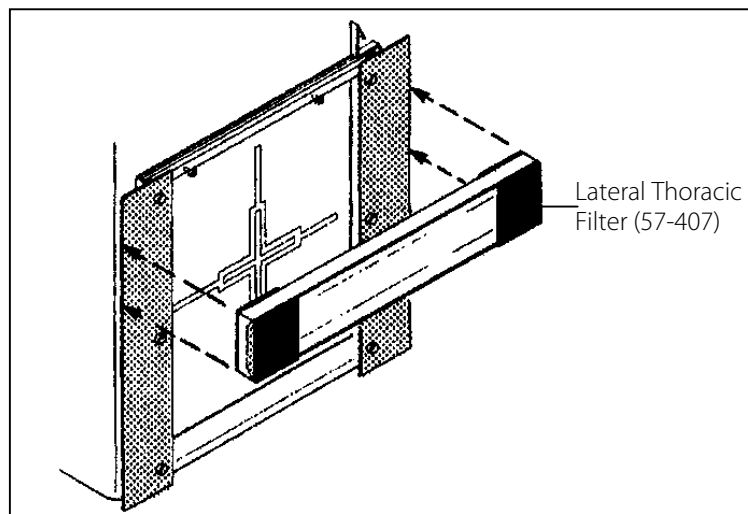

Figure 5-26.

5.13 Ribs (40" FFD)

40" AP/PA Filter (57-405)

The 40" AP/PA Filter is used to even out densities in the chest cavity as it increases in size. The thin end of the filter is in the caudad direction (see Figure 5-27). How low the filter is positioned depends on the shape of the patient.

NOTE

Filter is suggested for above-diaphragm application only.

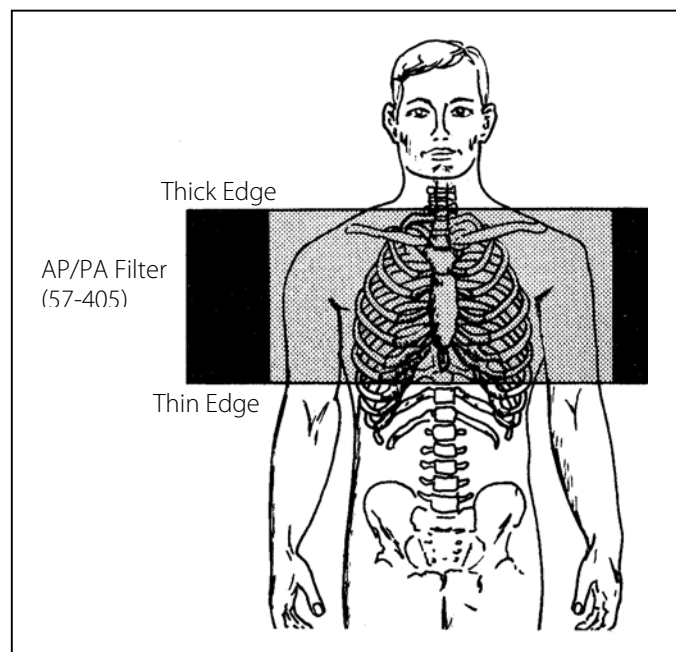

Figure 5-27.

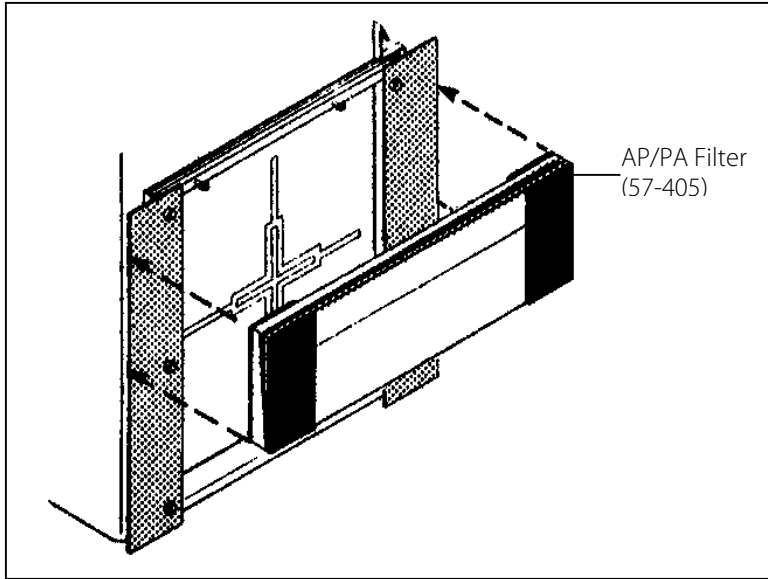

Figure 5-28.

(Blank page)

Radiation Management Services

For additional information, please contact
Radiation Management Services business
of Cardinal Health at 440.498.2564, or
516.870.0100



© 2003 Cardinal Health, Inc. or one of its subsidiaries
All rights reserved.
Manual No. 38609 Rev. 2 13 jan 04

Cardinal Health
6045 Cochran Road
Cleveland, Ohio 44139

120 Andrews Road
Hicksville, New York 11801

www.cardinal.com/rms